

Ultra-High Performance Jitter Attenuator (JA) and Frequency Multiplier (Fx)

Features

- Input frequency from 1 MHz to 750 MHz, gapped clock
- Output frequency from 10 MHz to 1000 MHz
- Ultra-Low Jitter (12 KHz to 20 MHz)
 - 34.9 fs at 156.25 MHz
 - 24.6 fs at 312.50 MHz
 - 26.1 fs at 491.52 MHz
 - 26.8 fs at 625 MHz
- CML/LVDS/LVDS-EXT/LVPECL/HCSL output formats
- Output Enable/Disable Feature
- < 10 ms start-up time
- 3.2X2.5 mm 8-pin LGA package
- Single 1.8V supply with internal regulator
- Superior power supply immunity
- Temperature range: -40°C to 85°C
- Temperature extended range: -40°C to 105°C
- ESD HBM 2000V, CDM 500V
- Lead free / RoHS compliant

Applications

- SATA
- 10 GbE LAN/WAN
- SAS
- Fiber Channel
- Clock and data recovery
- PCI-Express
- Instrumentation

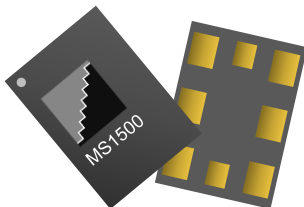

General Description

The MS1500 combines jitter attenuation and frequency multiplication in a single device. It is powered by our Virtual Crystal™ technology that enables ultra stable fully programmable multi-GHz clocks with extremely low phase noise.

Adaptive fully autonomous DSP algorithms running in the background continuously monitor and ensure robust and consistent performance over process, voltage, and temperature variations.

The product can take any input frequency from 1 MHz to 750 MHz and generate any output frequency from 10 MHz to 1000 MHz with <1ppb. The product is configured using factory programmed NVM.

The MS1500 is manufactured in a high-volume 28 nm CMOS process and represents the most advanced node in the timing industry.

Device Information

Part Number	Package	Description
MS1500	3.2X2.5 mm 8-pin LGA	Jitter Attenuator Frequency Multiplier

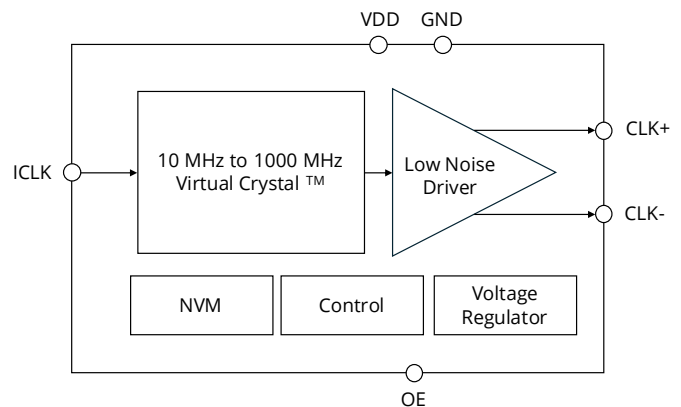

Figure 1. Functional Block Diagram

MS1500

Pin Assignment and Pin Description

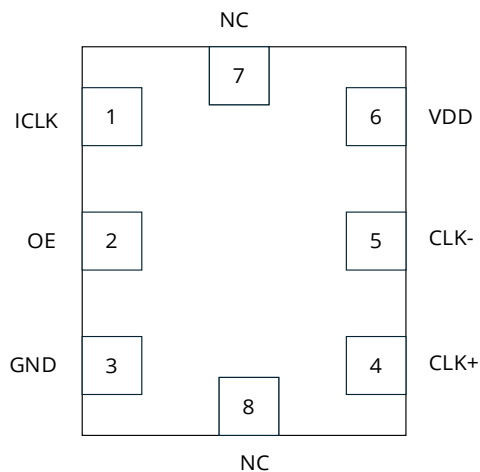

Figure 2. MS1500 Pin Assignments

Table 1. MS1500 Pin Descriptions

Pin No	Name	Description
1	ICLK	Reference CLK input
2	OE	Output Enable
3	GND	Ground
4	CLK+	Clock Output
5	CLK-	Complementary Clock Output
6	VDD	Power Supply
7	NC	No Connect
8	NC	No Connect

Specifications

Table 2. Electrical Specifications

Typical values are specified at $T_A = 25^\circ\text{C}$, $V_{DD} = 1.8\text{V}$ unless otherwise specified. All Min and Max limits are specified over the operating temperature range and voltage range with standard termination.

Parameter	Symbol	Test Condition/Comment	Min	Typ	Max	Unit
-----------	--------	------------------------	-----	-----	-----	------

Frequency Range

Input Frequency Range	I_{CLK}		1		750	MHz
Input Voltage Swing	I_{SWG}	AC-coupled	0.1		1.8	V _{pp-SE}
Output Frequency Range	F_{CLK}	All Output Formats	10		1000	MHz

Clock Output Jitter Characteristics

RMS Phase Jitter (12 KHz – 20 MHz)	Φ_{JITTER}	Frequency=312.5 MHz		24.6	37	fs
		Frequency=625 MHz		26.8	40	fs

Note:

Phase jitter measured on Agilent 5052B Signal Source Analyzer

Operating Voltage/Temperature Range

Supply Voltage	V_{DD}		1.71	1.8	1.89	V
Temperature Range	T_A	Industrial Temperature	-40		85	$^\circ\text{C}$
		Extended Industrial Temperature	-40		105	$^\circ\text{C}$

Current Consumption

Supply Current	I_{DD}	LVDS Output (Output Enabled)	80	100	mA
		All Other Outputs (Output Enabled)	90	110	mA
		Tristate Hi-Z (Output Disabled)	50	60	mA

Input Characteristics

Digital Input Levels (OE)	V_{IH}		$0.7XV_{DD}$		V
	V_{IL}			$0.3XV_{DD}$	V
Output Enable (OE)	T_D	Output Disable Time		3	us
	T_E	Output Enable Time		20	us
Input Signal Powerup Time	T_{PWR}	Time required from $0.9xV_{DD}$ until input signal	10		ms
Output Lock Time	T_{LOCK}	Time from input signal to a stable output	10		ms

PSRR Characteristics

Power Supply-Induced Phase Noise	PSPN	Spurs induced by 50mV power supply ripples (312.5MHz)		-114	dBc
Power Supply-Jitter Sensitivity	PSJS			0.1	fs/mv

Note:

(1) Measured with 50 mVpp ripple from 50 KHz to 1 MHz applied on VDD Pin

Output Characteristics

Output Duty Cycle	DC	All Output Formats	48		52	%
Output Rise/Fall Time (20% to 80% V _{PP})	T _R / T _F	All Output Formats		65	100	Ps
LVDS Output (AC Mode)	V _{pp}	Differential Pk-Pk	0.5	0.7	0.9	V
LVDS Extended Output (AC Mode)	V _{pp}	Differential Pk-Pk	0.8	1.2	1.6	V
CML Output (AC Mode)	V _{pp}	Differential Pk-Pk	0.6	0.8	1	V
LVPECL Output (AC Mode)	V _{pp}	Differential Pk-Pk	1.2	1.4	1.6	V
HCSL Output	V _{pp}	Differential Pk-Pk	1.1	1.35	1.6	V
HCSL Output Voltage	V _{CM}	Common Mode Voltage	340	350	360	mV

Table 3. Absolute Maximum Ratings

Parameter	Min	Max	Unit
1.8V Supply Voltage	-0.3	1.98	V
Digital I/O	-0.3	1.98	V
Maximum Operating Temperature		105	°C
Storage Temperature	-55	150	°C
Soldering Temperature		260	°C
Junction Temperature		150	°C

Note: Stresses that exceed what is listed in this table may cause permanent damage to the device. Exposure to conditions above the recommendations for extended periods of time may affect device reliability.

Table 4. Environmental Compliance

Parameter	Test Condition
Mechanical Shock	MIL-STD-883, Method 2002
Mechanical Vibration	MIL-STD-883, Method 2007
Moisture Sensitivity Level (MSL)	3

Note: For additional information not listed, please contact Mixed-Signal Devices.

Table 5. ESD Levels

Description	Description	Specification	Level
HBM ¹	Human Body Model	JEDEC JS-001	2000V
CDM ²	Charge Device Model	JEDEC JESD22-C101	500V
Notes: 1. 1000V HBM allows safe manufacturing with standard ESD control process – JEDEC document JEP155 2. 250V CDM allows safe manufacturing with standard ESD control process – JEDEC document JEP157			

Table 6. Package Thermal Information

Package	Parameter	Symbol	Value	Unit
3.2mmX2.5mm 8 pin LGA	Thermal Resistance, Junction to Ambient	θ_{JA}	80	°C/W
	Thermal Resistance, Junction to Board	θ_{JB}	40	°C/W
	Air Flow Condition		0	Mps
	Maximum Junction Temperature	T_J	125	°C
Note: The thermal resistance information stated in this table is based on a standard JEDEC PCB condition. The actual thermal resistance varies depending on the customer PCB design.				

Table 7. Typical Output Phase Noise Characteristics
 VDD= 1.8V, T_A = 25°C, Output Type = LVDS-EXT

Offset frequency	156.25 MHz	312.50 MHz	491.52 MHz	625 MHz	Unit
1 KHz	-106	-103	-100	-98	dBc/Hz
10 KHz	-138	-133	-128	-127	dBc/Hz
100 KHz	-157	-154	-149	-147	dBc/Hz
1 MHz	-167	-163	-158	-156	dBc/Hz
10 MHz	-168	-164	-160	-148	dBc/Hz
20 MHz	-168	-164	-159	-158	dBc/Hz
RMS Jitter (12 KHz – 20 MHz)	34.9	24.6	26.1	26.8	fs

Typical Output Measured Phase Noise Plots

This section shows four MS1500 performance plots.

Measurement parameters are: VDD = 1.8 V, TA = 25°C, Output Type = LVDS-EXT.

The plots were captured using an Agilent 5052B Signal Source Analyzer.

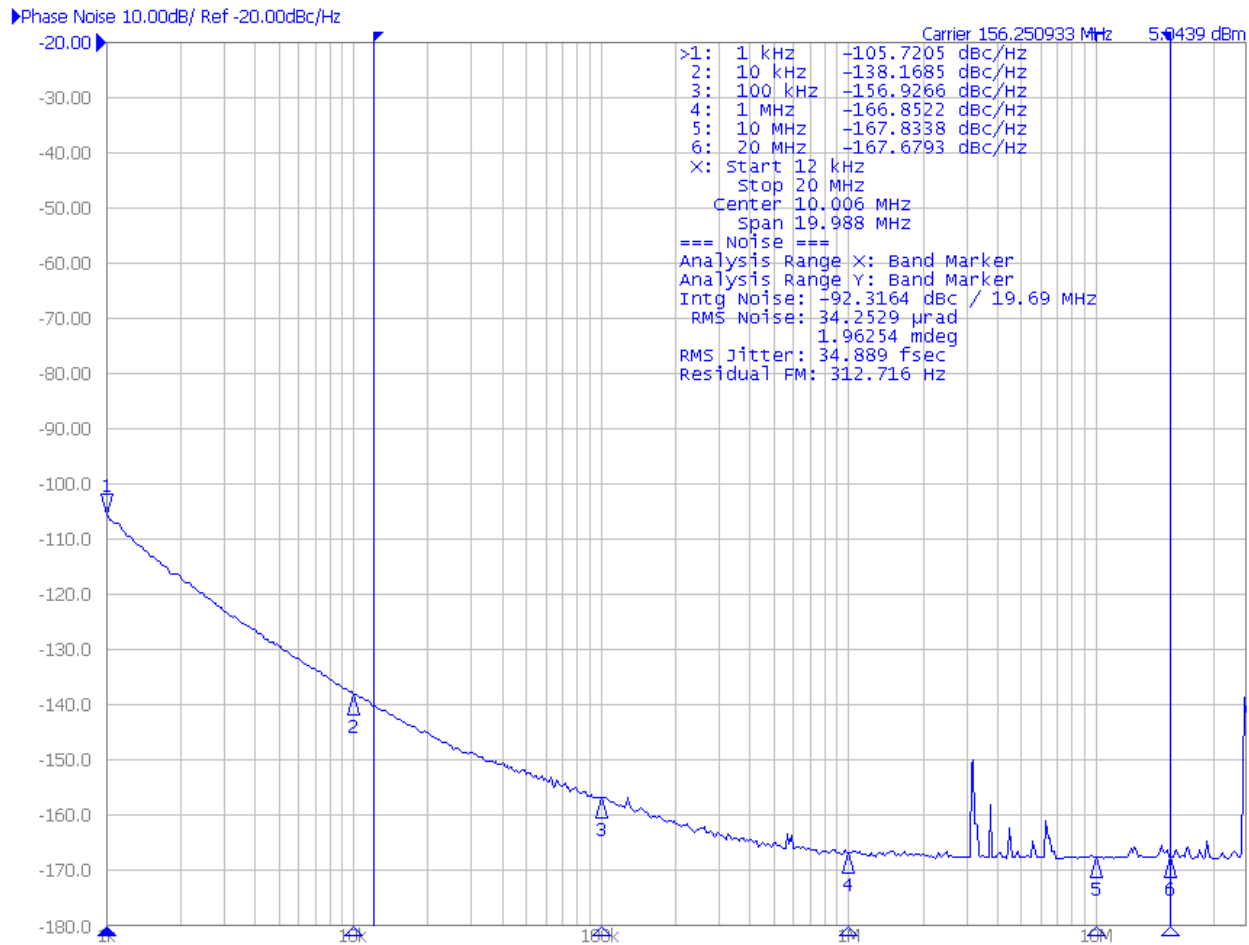

Figure 3. Carrier: 156.25 MHz

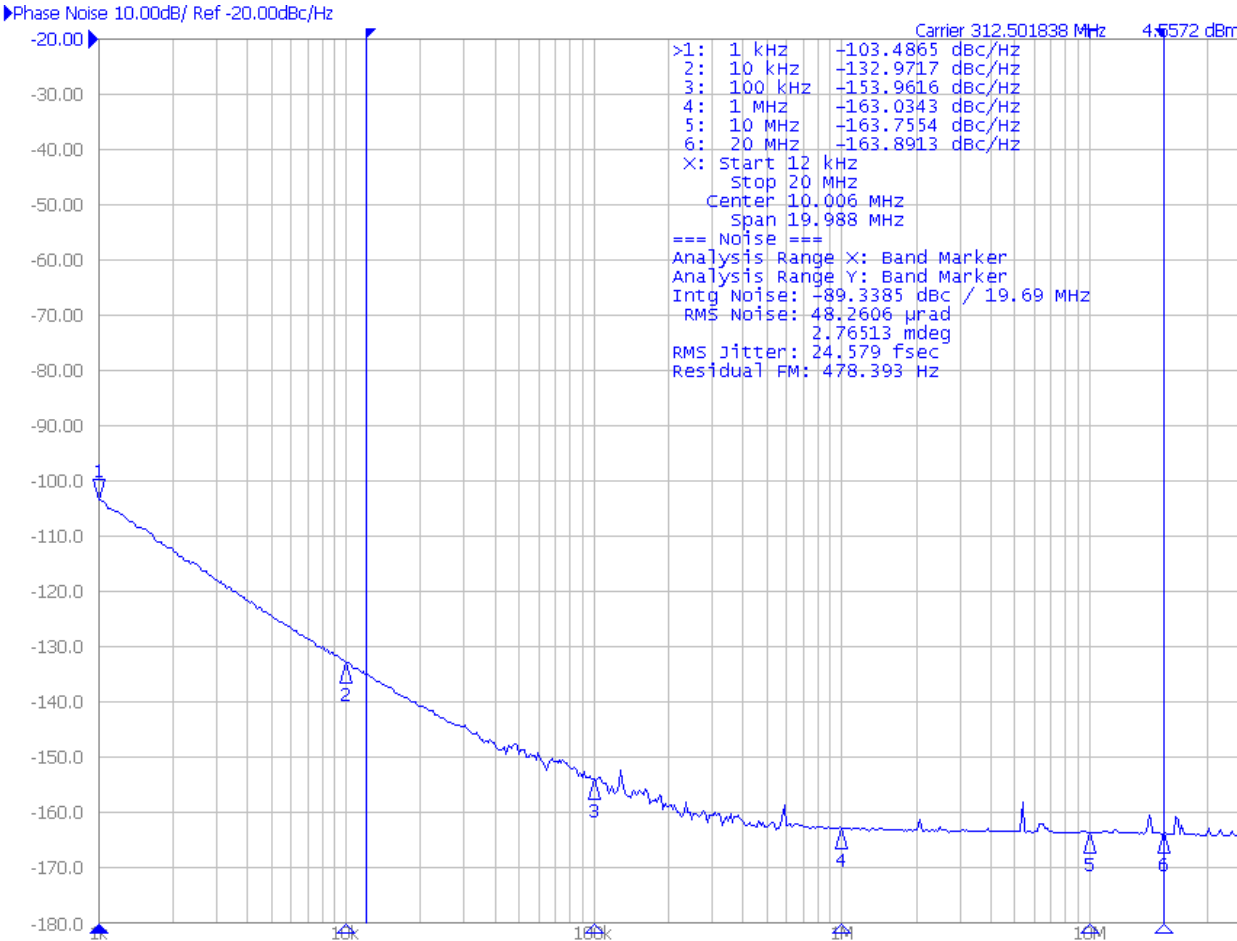

Figure 4. Carrier: 312.5 MHz

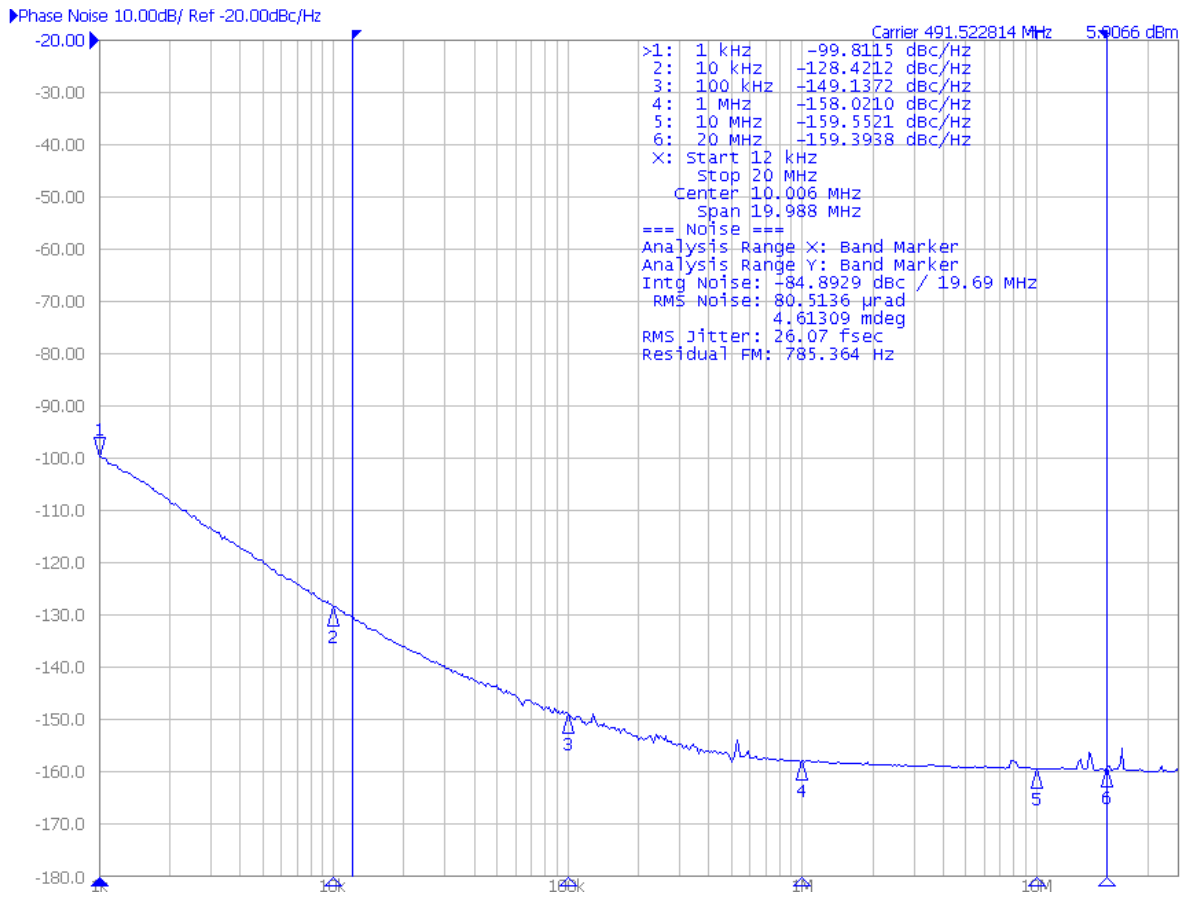

Figure 5. Carrier: 491.52 MHz



Figure 6. Carrier: 625 MHz

Overview

The MS1500 is a single channel high-performance Jitter Attenuator that offers exceptional capabilities in the generation of an ultra-low phase noise clock, making it an ideal solution for next-generation communication systems and base stations. This device can produce one differential output clock synchronized to the reference clock input with input frequency ranging from 1MHz to 750MHz single-ended, and gapped clock support. The MS1500 boasts an output frequency range of 10MHz to 1GHz and a remarkably low RMS jitter of 30fs (12KHz to 20MHz), making it one of the most reliable and precise devices available.

The device's programmability is configured by on-chip non-volatile memory (NVM). This attribute permits the MS1500 to provide great flexibility and ease of use in a broad range of applications, including telecommunications, networking, and test and measurement equipment.

Functional Description

The MS1500 is an all-digital Phase-Locked Loop (PLL) that incorporates a range of features to enable jitter attenuation and programmable multiplication of input frequency. It receives one reference clock input and generates any multiplication of the input clock using fractional multipliers and high-speed output divider. The device can output various formats, such as LVDS, LVDS EXT, CML, LVPECL, and HCSL.

1. Frequency Configuration

The frequency configuration of the PLL is programmable through the serial interface and can also be stored in non-volatile memory. The combination of fractional frequency multiplication (M/N) and integer output division (Rn) allows the generation of any output frequency on any of the outputs. Fractional multiplication ratio and output divider ratio values can be easily calculated by the EZ-cleaner GUI utility.

2. PLL loop bandwidth

The PLL loop bandwidth determines the amount of input clock jitter attenuation. Register configurable PLL loop bandwidth settings in the range of 0.01 Hz to 4 kHz are available for selection in the EZ-cleaner GUI utility. Since the loop bandwidth is controlled digitally, the PLL will always remain stable with less than 0.1 dB of peaking regardless of the loop bandwidth selection.

Operation Modes

Free Running Mode (Default Mode)

After initialization, MS1500 will enter free running mode. In this mode, the device generates an output clock using multiplication factor stored in the on-chip NVM. The frequency accuracy of the generated output clock tracks the frequency accuracy of the input reference. For example, if the input frequency is 156.25 MHz (+/- 10ppm) and the stored multiplication factor is 33/32, the output frequency would be 161.1328125 MHz (+/- 10ppm).

Lock Acquisition Mode.

Upon completion of the configuration process, the MS1500 will transition into lock acquisition mode. This mode comprises two stages: fast acquisition and narrow acquisition. In the first stage, the loop bandwidth is widened to facilitate a speedy initial acquisition process. Following this, the bandwidth is narrowed as the device completes the lock.

Output

MS1500 supports CML, LVDS, LVDS-EXT, LVPECL, and HCSL output formats. The output enable, OE, is active HI. When OE is LOW, MS1500 output will be High Z but the loop will stay locked.

Input Terminations

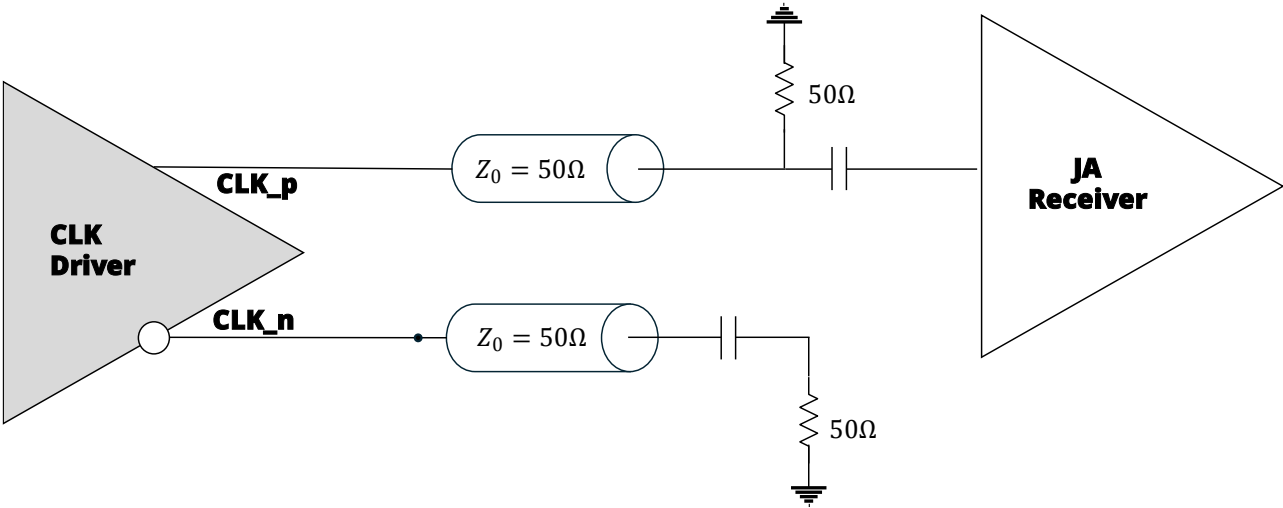

Figure 7. Differential Input Interface

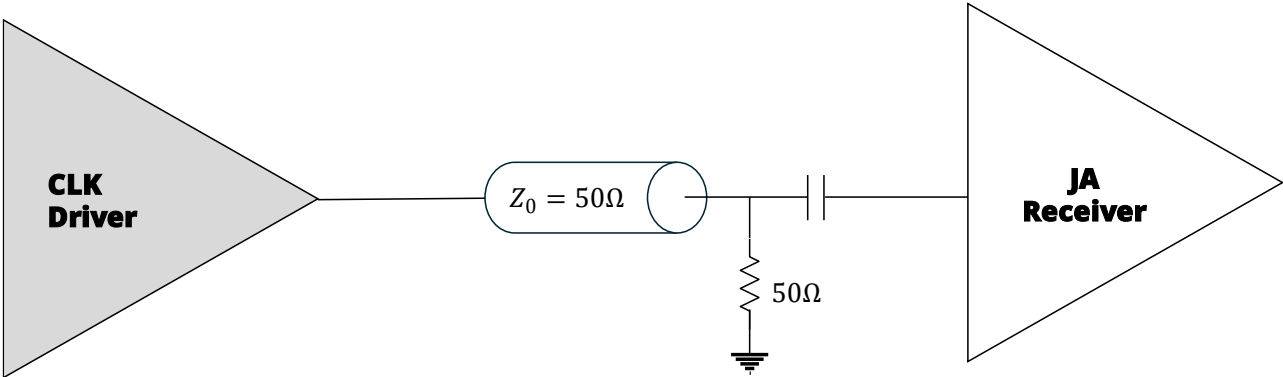

Figure 8. Single-Ended Input Interface

Output Terminations

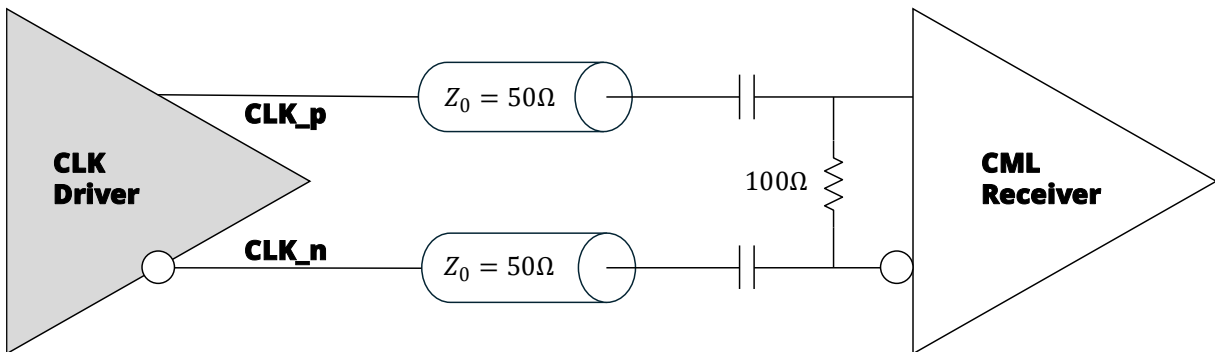

Figure 9. AC-Coupled CML

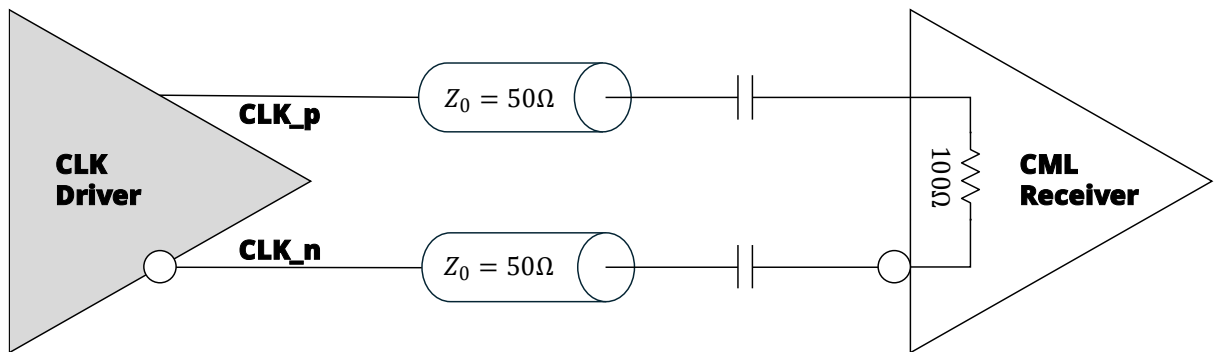

Figure 10. AC-Coupled CML (Receiver Termination)

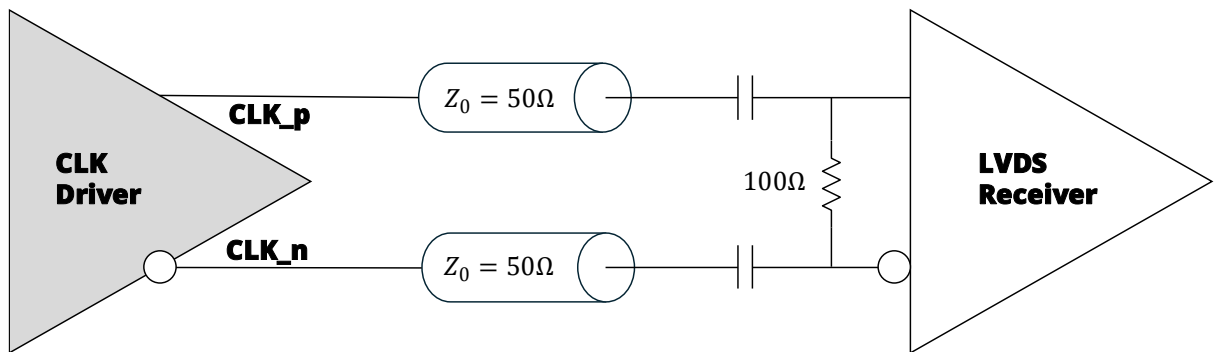

Figure 11. AC-Coupled LVDS

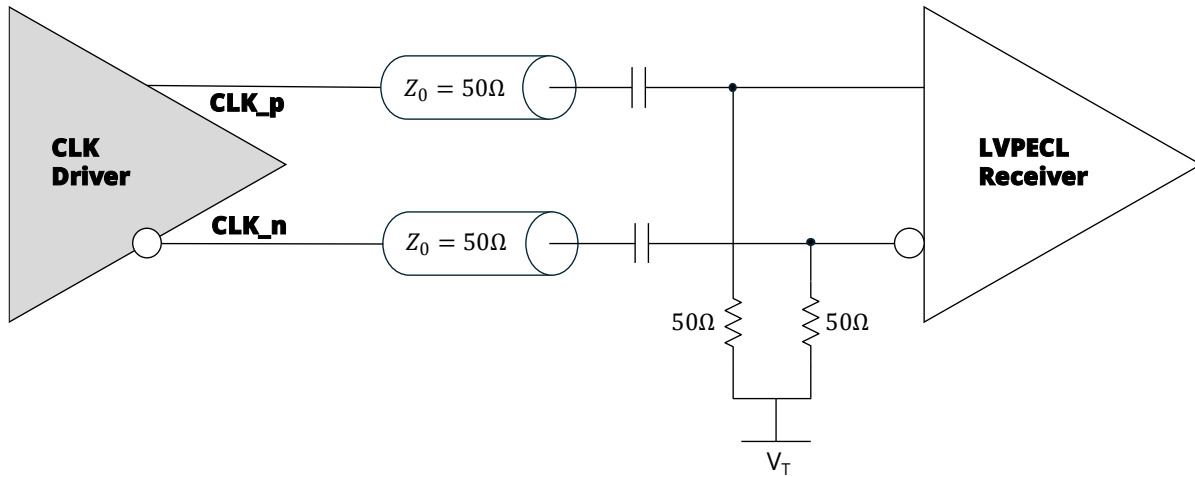

Figure 12. AC-Coupled LVPECL

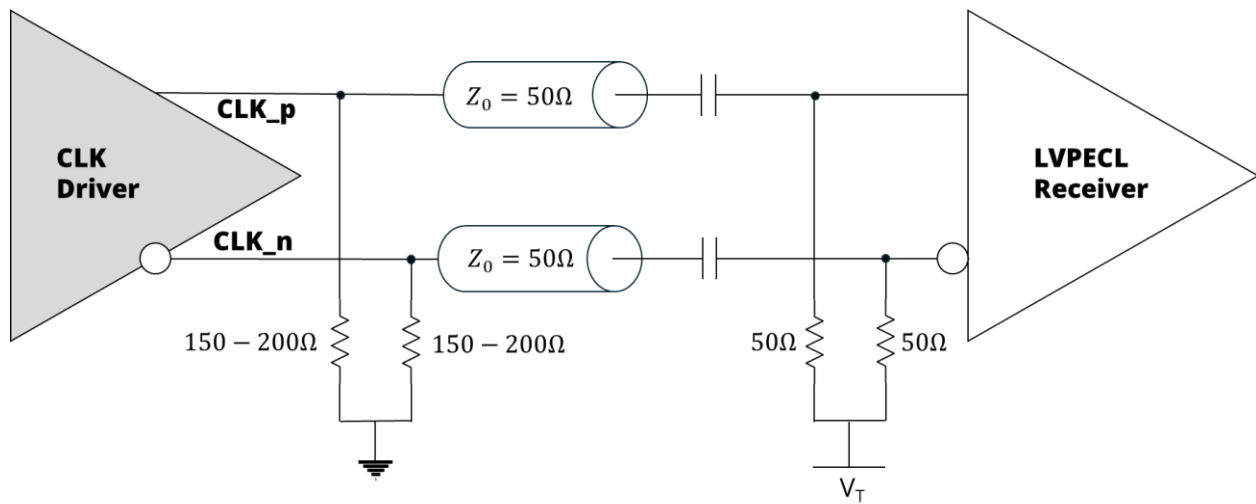

Figure 13. AC-Coupled LVPECL (DC Bias Resistor)

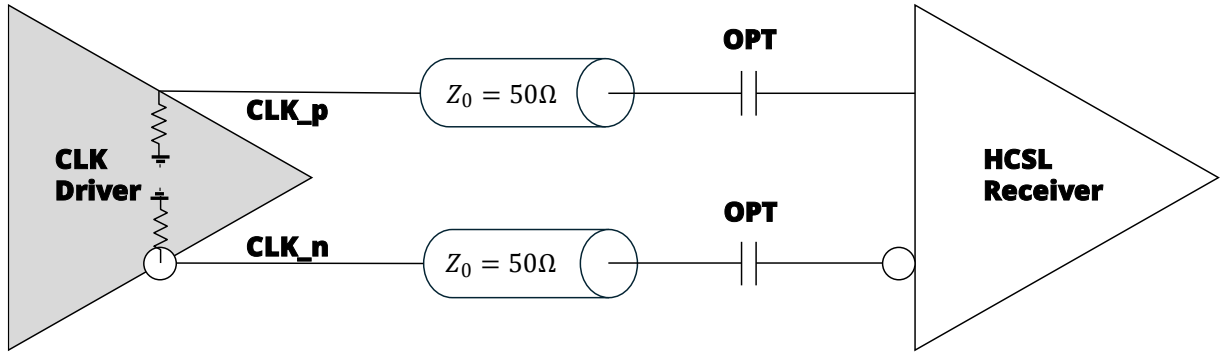

Figure 14. HCSL (Integrated Termination)

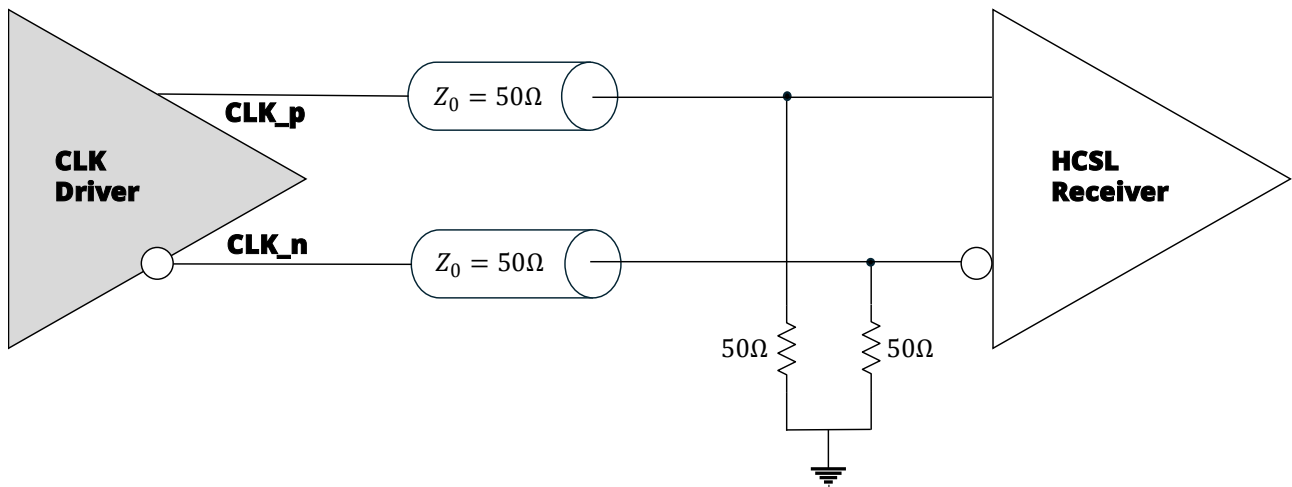

Figure 15. DC-Coupled HCSL (Receiver Termination)

Output Timing

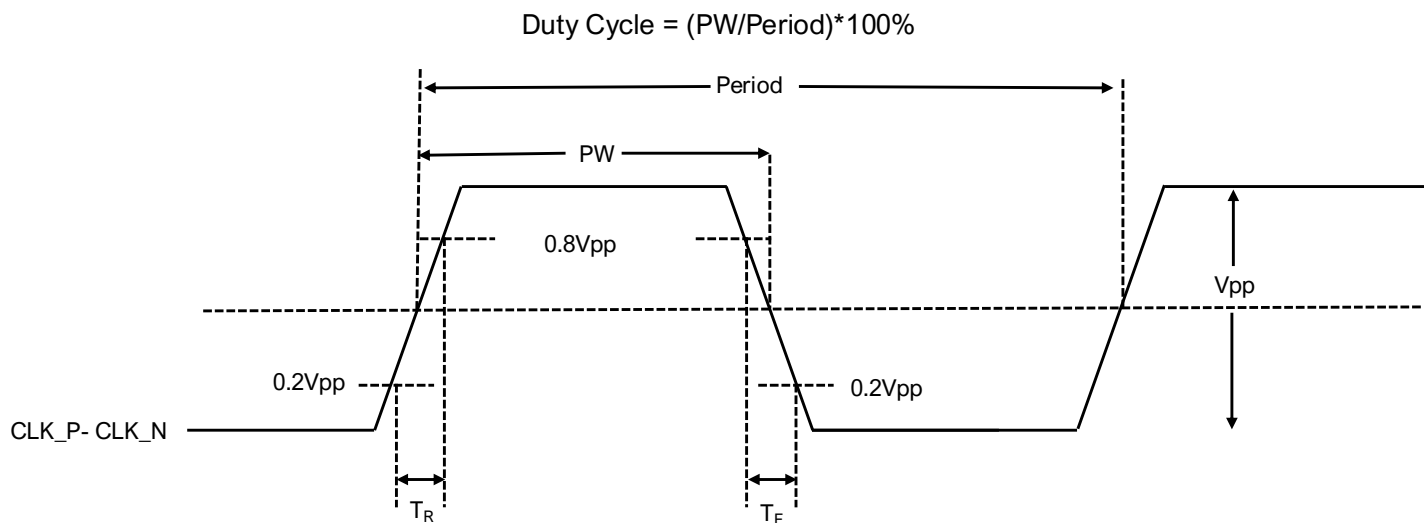

Figure 16. Output Timing across differential pair (CLK_P-CLK_N)

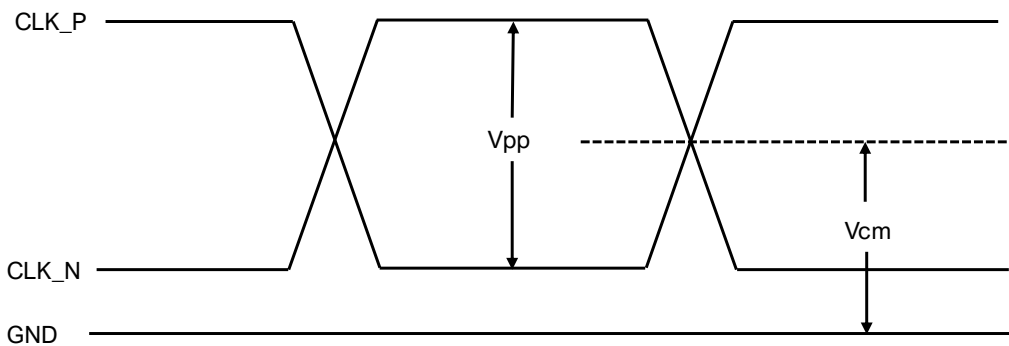

Figure 17. HCSL Output Level across differential pair (CLK_P-CLK_N)

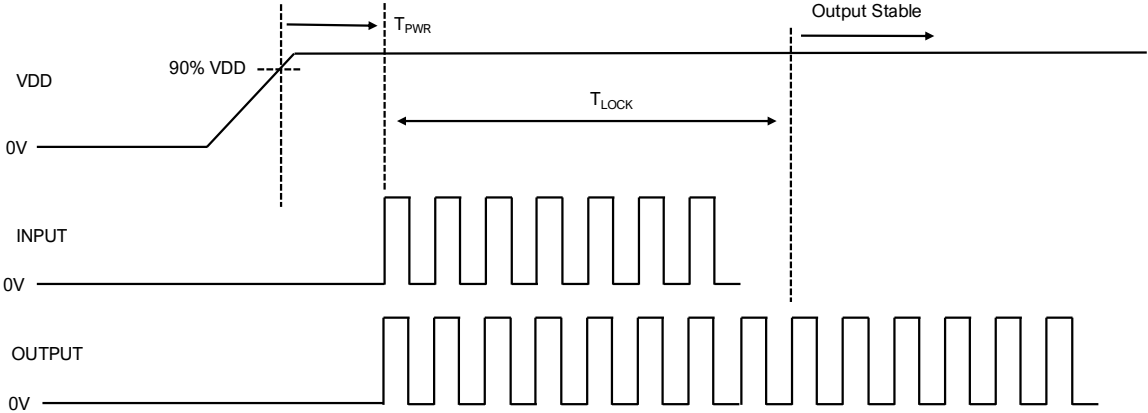

Figure 18. Powerup Timing Input/Output

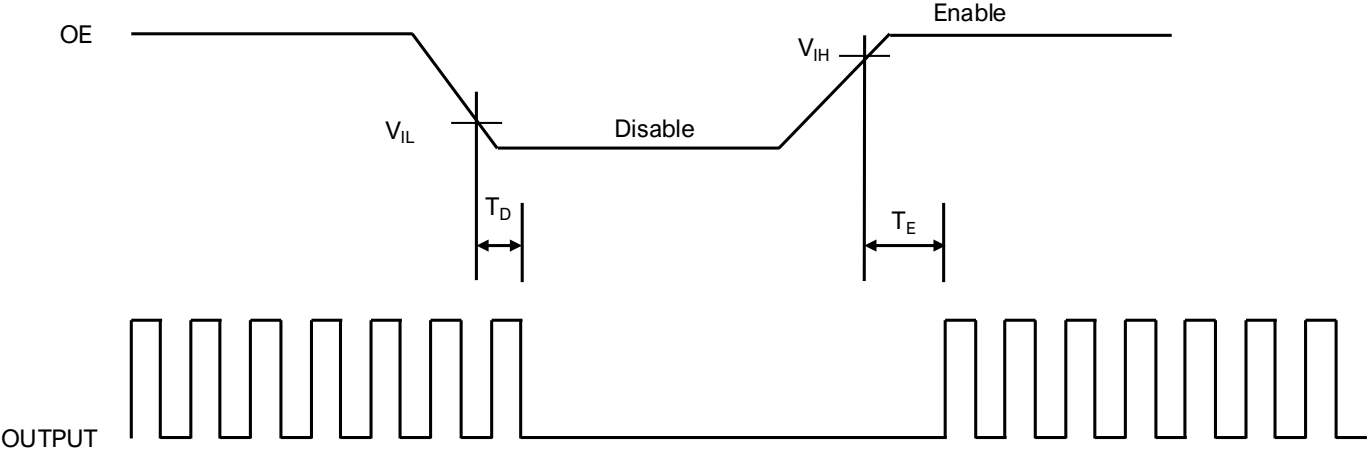

Figure 19. OE Enable/Disable Timing

Packaging Information

Figure 20 shows the MS1500 packaging drawing.

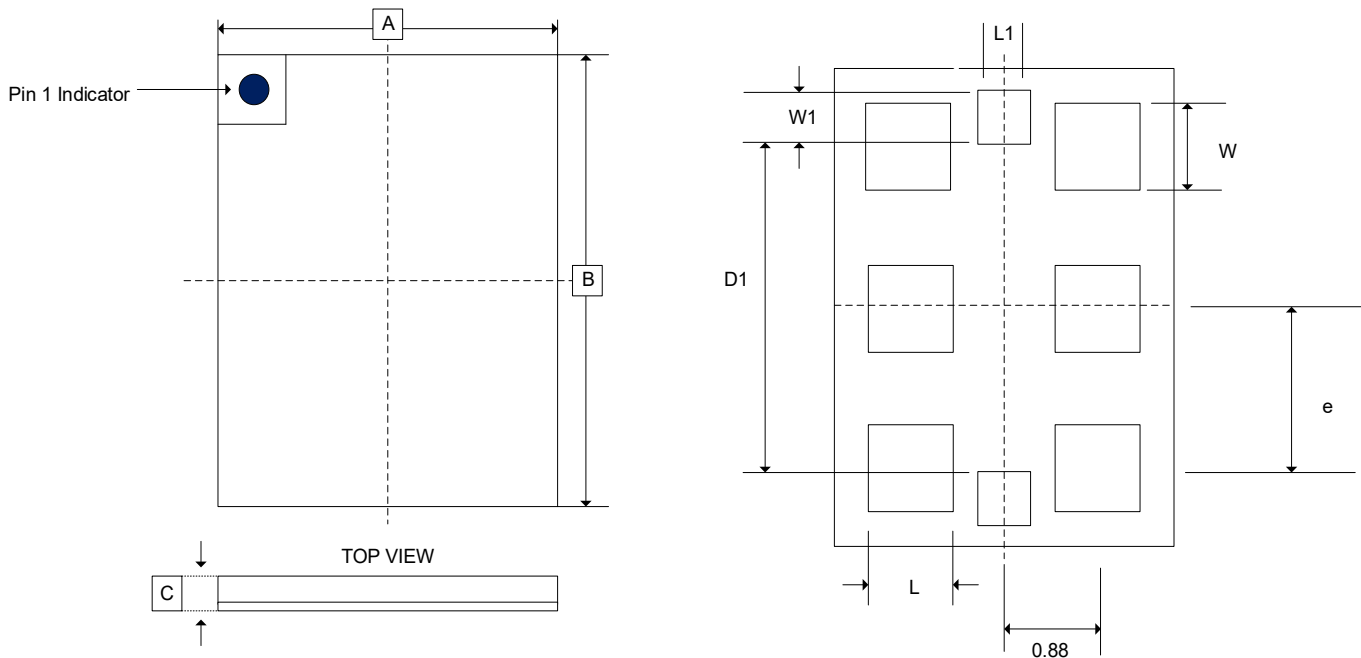

Figure 20. MS1500 Packaging Drawing (3.2mm x 2.5 mm)

Table 8. MS1500 Packaging Dimensions

Dimensions	Min	Nom	Max
A	2.5 BSC		
B	3.2 BSC		
C	1.246	1.346	1.446
W	0.55	0.6	0.65
L	0.5	0.55	0.6
W1	0.35	0.4	0.45
L1	0.35	0.4	0.45
e	1.1 BSC		
D1	2.2 BSC		
Package Edge Tolerance	0.1		
Mold Flatness	0.1		
Coplanarity	0.08		

Note: All dimensions are in millimeters

Packaging Land Pattern

Figure 21 shows the MS1500 PCB land pattern.

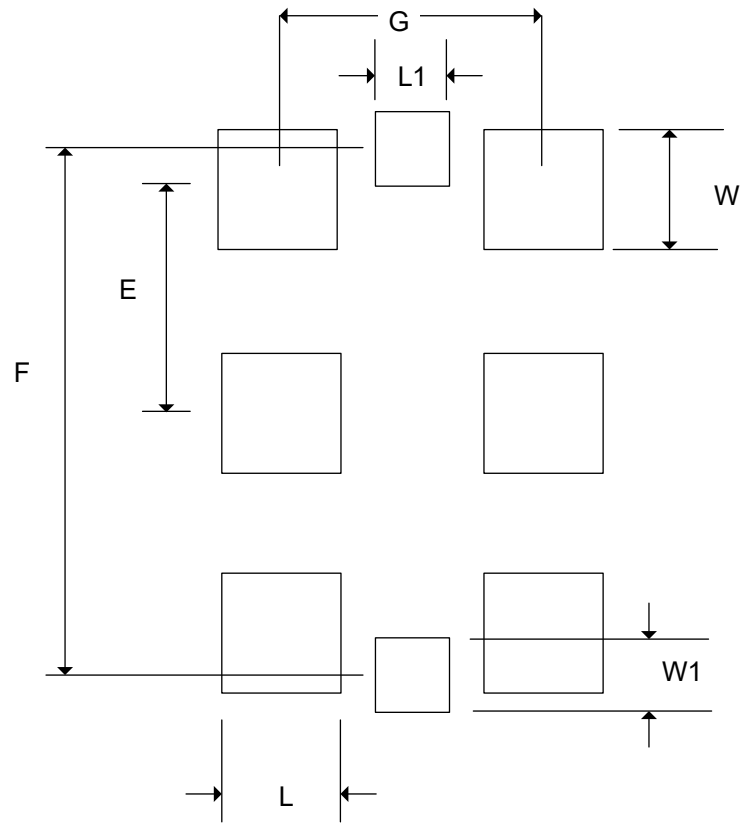

Figure 21. MS1500 Packaging Land Pattern Drawing (3.2mm x 2.5mm)

Table 9. MS1500 Packaging Land Pattern Dimensions

Dimensions	In mm
L	0.7
W	0.7
L1	0.5
W1	0.55
E	1.1
F	2.6
G	1.76

Device Top Marking

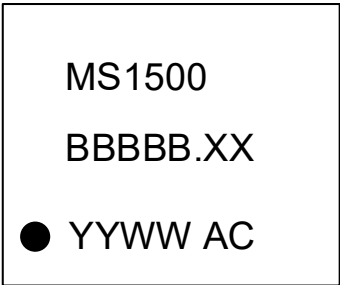

Figure 22. MS1500 Device Top Marking Showing Pin 1

Table 10. MS1500 Device Marking Legend

Line	Position	Description
1	1	Part Number
2	1-5	Wafer Lot Number
	6-7	Wafer #
3	Lot Traceability	
	1	Pin 1 Orientation Mark (Dot),
	2-3	Year (last two digits of the year)
	4-5	Calendar Work Week Number (1-53)
	6-7	Assembly Code

Part Ordering Information

Figure 23 shows a logic tree for ordering each of the three available parts.

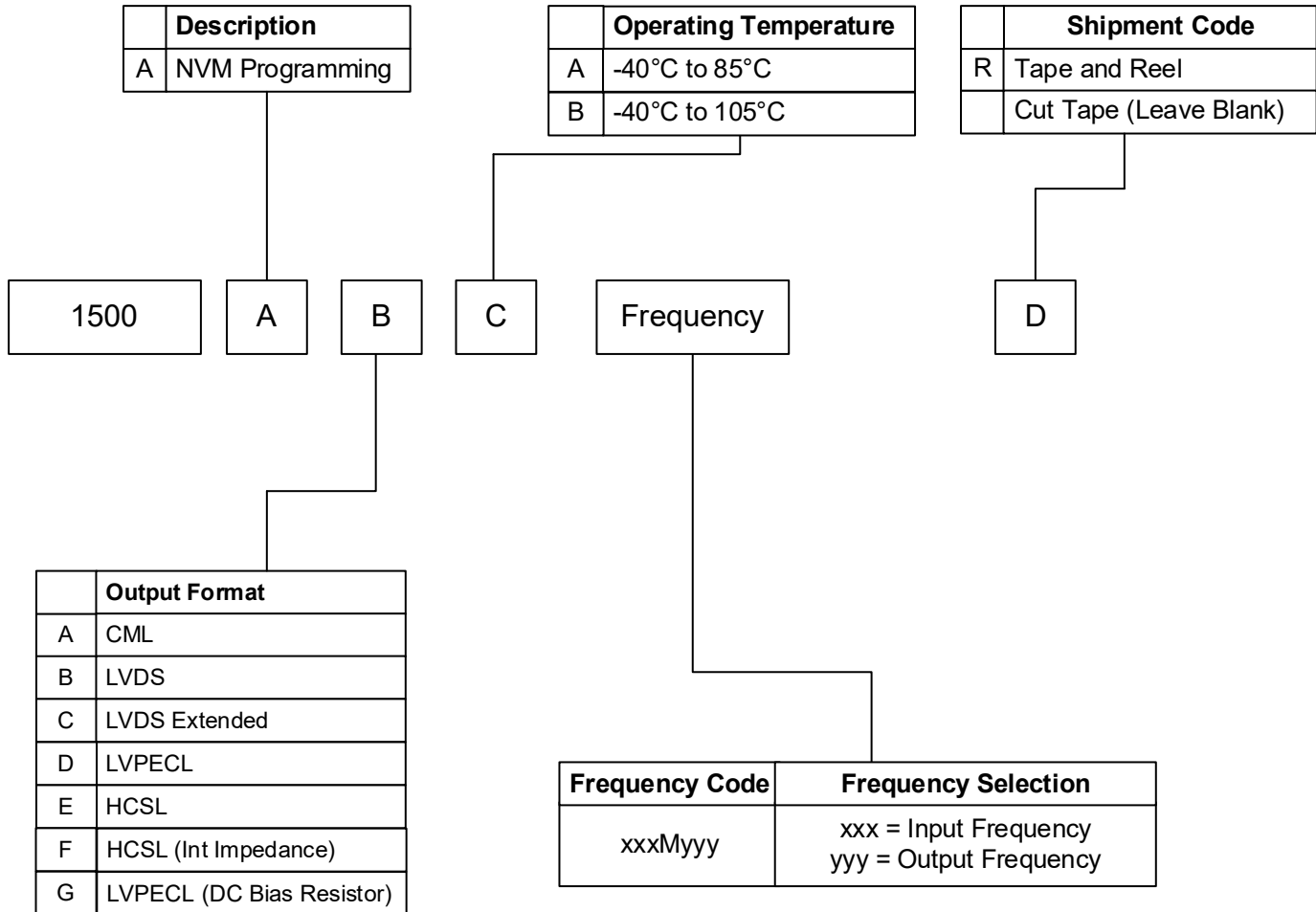

Figure 23. MS1500 Part Ordering Information

Table 11. Example of ordering part number

Base P/N	Output Format	Operating Temperature	Input Frequency	Output Frequency	Shipment Type	Ordering part number
1500	HCSL	-40°C to 85°C	156 MHz	312.5 MHz	Tape and Reel	1500AEA156M312R
1500	LVPECL	-40°C to 105°C	312.5 MHz	625 MHz	Tape and Reel	1500ADB312M625R

Input/Output Frequency codes for ordering

Code (xxx)	Frequency (MHz)	Code (yyy)	Frequency (MHz)
001	1	050	50
100	100	100	100
106	106.25	106	106.25
122	122.88	122	122.88
153	153.6	153	153.6
156	156.25	156	156.25
212	212.5	212	212.5
245	245.76	245	245.76
250	250	250	250
307	307.2	307	307.2
312	312.5	312	312.5
322	322.2656525	322	322.2656525
491	491.52	491	491.52
500	500	500	500
614	614.4	614	614.4
625	625	625	625
644	644.53125	644	644.53125
750	750	983	983.05

Please contact Mixed-Signal Devices for additional frequency codes

Reflow Profile (IPC/JEDEC-STD-020)

Figure 24 shows the reflow profile for MS1500

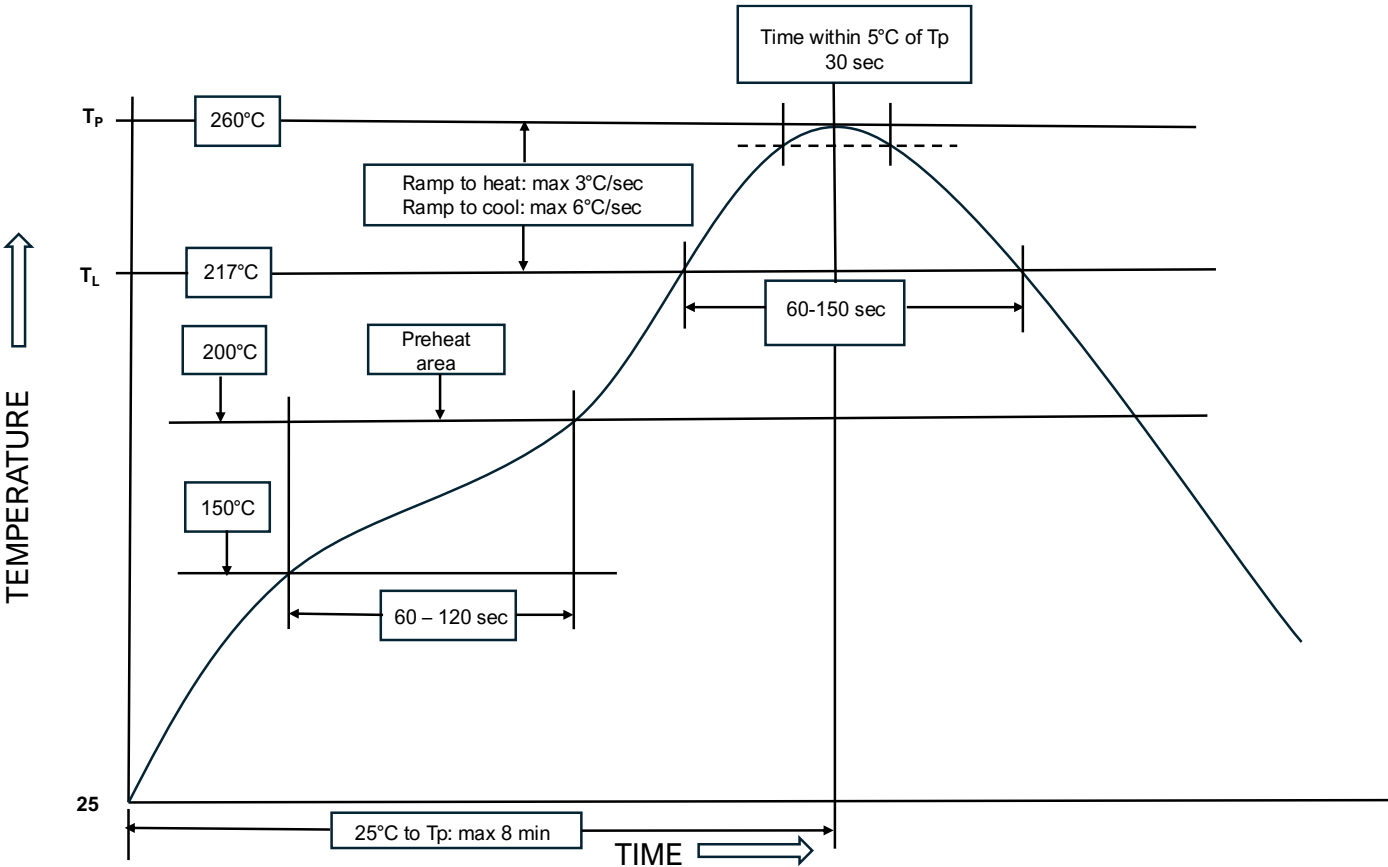

Figure 24. MS1500 Reflow Profile

REVISION HISTORY

Revision 1.4

April 20, 2026

- Added LVPECL Load Termination
- Updated ordering part number (include LVPECL Load Termination)

Revision 1.3

November 14, 2025

- Updated Product Title

Revision 1.2

October 17, 2025

- Updated Figure 13: Output Driver (HCSL); removed AC coupling
- Updated ordering part number

Revision 1.1

September 2, 2025

- Added Timing Diagram
- Updated Output Driver information (LVPECL, HCSL)
- Added Reflow Profile

Revision 1.0

December 20, 2024

- Initial Release

IMPORTANT NOTICE AND DISCLAIMER

MIXED-SIGNAL DEVICES INC. PROVIDES TECHNICAL AND RELIABILITY DATA (INCLUDING DATASHEETS), DESIGN RESOURCES (INCLUDING REFERENCE DESIGNS), APPLICATION OR OTHER DESIGN ADVICE, WEB TOOLS, SAFETY INFORMATION, AND OTHER RESOURCES “AS IS” AND WITH ALL FAULTS, AND DISCLAIMS ALL WARRANTIES, EXPRESS AND IMPLIED, INCLUDING WITHOUT LIMITATION ANY IMPLIED WARRANTIES OF MERCHANTABILITY, FITNESS FOR A PARTICULAR PURPOSE OR NON-INFRINGEMENT OF THIRD-PARTY INTELLECTUAL PROPERTY RIGHTS.

Mailing Address: Mixed-Signal Devices Inc, 2 Venture, Suite 300, Irvine, California 92618, USA Copyright © 2024